

Senger News & Focus

Senger and Associates, Inc.

www.senger-assoc.com

Summer 2004

Lindar Corporation – Small Enough to Care, Big Enough to Deliver

Lindar - Thermoformer for Packaging and OEM Markets

Recently Senger and Associates began representing Lindar Corporation, a plastic thermoforming company located in Baxter, Minnesota. The Lindar Corporation designs, prototypes, and manufactures plastic thermoformed products and packaging for the OEM market.

Thin Gauge Roll Fed Manufacturing

In thin gauge manufacturing, Lindar forms a variety of materials such as ABS, PET, HDPE, OPS, HIPS and PVC.



Material thickness ranges from .007" to .080". In this process Lindar uses a wide variety of trimming methods including matched-metal, cut in place and steel rule/forged dies. Examples of thin gauge products include clamshells, blisters, industrial packaging, shelf

organizers, shipping/handling trays, and specialty items.

Heavy Gauge Cut Sheet Manufacturing

Lindar forms a variety of heavy gauge materials such as ABS, HDPE and HIPS, and material thickness ranges from .050" to .500". A few examples of Lindar's custom-engineered components include trays, seats, guards, hoods, tubs and displays.



Lindar: A Cut Above the Rest

One of the keys to Lindar's success is flexibility. Regardless of heavy gauge or thin gauge material; matched metal, cut in place, or steel rule die, they thrive on exceeding customer expectations utilizing several manufacturing processes with a group of people who understand customer expectations. Lindar serves a diverse group of customers in the packaging and OEM markets – through these partnerships Lindar provides the finest products and service in the thermoforming industry.

For more information on the Lindar Corporation, please contact Senger and Associates, Inc. at (651) 633-6040.

Contour Adds 400-Ton Press



Contour Plastics, a leading manufacturer of rapid turn-around injection molded production parts and assemblies, has been adding new equipment to meet the increasing demand for insert overmolding, true 2-shot, and secondary/assembly capabilities. The most recent acquisition is a new 400-ton Nissei electric press. As a result, Contour Plastics now offers press-clamping capability from 40 tons to 400 tons. This allows Contour to mold very small parts to larger parts up to approximately 150 square inches.

Contour Plastics, located in Baldwin, Wisconsin, is both ISO – 9000 certified and is also a registered manufacturer with the FDA.

Mendell Corp: Technology with a Personal Touch

Senger and Associates, Inc. now represents Mendell Corporation, a general machining company specializing in prototyping, quick turn-around machining, and short runs.

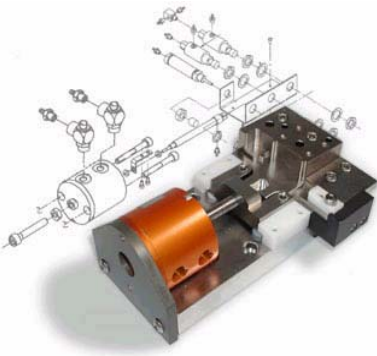

Mendell, a medium-sized, machine-tool intensive shop located in Lakeville, Minnesota, strives to make sure every job is done to their customer's specifications, whether

the customer is looking for complete (design through production) or while-you-wait service.

Mendell Offers Many Services

Mendell is a full-service shop, offering personal attention and tools needed to take a job from conception to delivery. Mendell offers:

- ▶ Mechanical engineering
- ▶ Mechanical – electrical and pneumatic
- ▶ Vertical and horizontal NC milling and CNC milling
- ▶ CNC and Swiss Turning
- ▶ Solid model rendering
- ▶ Certified inspection
- ▶ Prototyping
- ▶ Production
- ▶ Assembly

In addition, Mendell specializes in prototypes, small runs, and the fastest turnaround time in the business – depending on the size and scope of the job, they can have it ready the next day, or even while you wait.



Mendell's Highly Skilled Professionals

Mendell's team of highly skilled professionals radiates a unique sense of pride, enthusiasm and personal commitment to Mendell and their customers. It's a

dedication uncommon in today's marketplace – and one that sets Mendell apart from the competition.

That commitment follows through in Mendell's ongoing effort to enhance their skills through continuing education and hands-on experience with the latest communications, computer and machine tool technology.

Rimex: Specialists in Textured Metals

With comprehensive manufacturing facilities in the USA, the UK, Australia and South Africa; stocking and distribution companies in Germany, Ireland, France and Spain; and a global network of agents and distributors, the Rimex Group is capable of delivering to anywhere in the world an extensive selection of dynamic finishes on a range of metals suitable for engineering, industrial, architectural, retail, transport, and product applications.

Additionally, Rimex has now added 60" wide materials in the Leathergrain pattern, as well as the 5-SM and Tread-Tex materials. These patterns, made of anti-graffiti steel, hide scratches, dents, and wear and tear far more effectively than a # 4 polished stainless steel.



Rimex's Leathergrain Pattern

To Learn More

If you would like to learn more about the Rimex or Mendell Corporations, the Lindar Corporation, Contour Plastics or any of the other lines the Sengers represent, contact Senger and Associates, Inc. at (651) 633-6040 or visit their website at www.senger-assoc.com.

The Senger and Associates Vision Statement:

To be recognized by manufacturing companies as the preferred sales agency in Minnesota that operates with the highest standards and ethics.